



Accelerating Revenue Through Carrier Ethernet Service Differentiation

Seizing opportunities for growth
with Carrier Ethernet services

Content

Facing the “Revenue Crunch”	4
Seizing Opportunities for Growth with Carrier Ethernet Services	5
Building Differentiated Carrier Ethernet Services	7
The Need for Performance Management Standardization	10
MEF Definitions for Carrier Ethernet Performance Management	13
KPIs for Carrier Ethernet Service Performance Assurance	17
Service Modelling for Carrier Ethernet Service Performance Assurance	21
Conclusion	21

Facing The “Revenue Crunch”

Communication Service Providers (CSPs) face significant challenges compared to their traditional business models built upon selling voice and data services over dedicated-circuit networks. Market saturation of these services and a global economic recession has caused overall revenue levels to flatten or decrease altogether. At the same time, demand for increased bandwidth and data services that support complex performance requirements has grown rapidly.

This has been driven by the explosion of traffic from bandwidth hungry enterprises, virtualized data centers, video and telepresence services, residential broadband, and of course mobile backhaul traffic – all of which are demanding a more cost-effective, scalable, and tailored set of data and voice services.

Consequently, CSPs find themselves in what the TM Forum has termed the Communications Industry’s “Revenue Crunch.” On the one hand, they are required to make significant capital investments in infrastructure to handle the rapidly accelerating network bandwidth demands. On the other hand, the dollar value for these services is decreasing and ultimately affecting margins.

The market for Carrier Ethernet services is proving to be the CSP’s salvation in this environment of revenue and margin pressure.

Carrier Ethernet has provided the means to more rapidly and efficiently deliver both the bandwidth requirements and service requirements of today’s businesses. Although this presents a great revenue opportunity, delivering Carrier Ethernet services can actually increase a CSP’s operating costs if not properly managed, especially with regards to delivering on performance requirements and SLAs.

Effective cost management can be achieved if a CSP’s management systems and processes adhere to Carrier Ethernet-based standards such as those codified by the Metro Ethernet Forum (MEF).

Not only is performance management necessary in addressing effective operations from the Service Desk through to Engineering & Planning, it also represents the service “proof-point” for CSPs to their customers. In fact, in a 2010 survey conducted by Atlantic-ACM, performance is cited as the number one purchase driver for Metro Wholesale services.

Thus an effective MEF-aligned performance management solution is critical to driving new business by differentiating a CSP’s Carrier Ethernet offering from its competitors, and simultaneously minimizing delivery costs and Service Level Agreement (SLA) penalties.

In fact, such a performance management solution can be leveraged to directly generate additional revenues by providing CSP customers enhanced visibility, hands-on troubleshooting, and premium reporting capabilities.

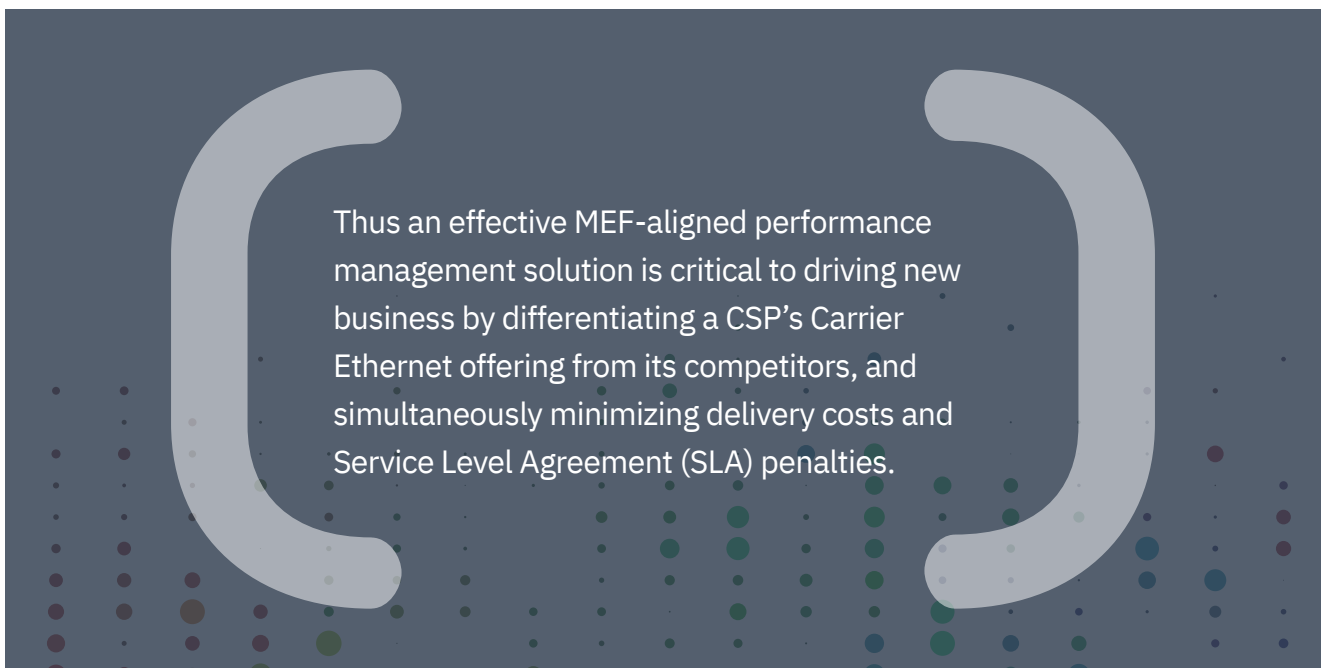

Seizing Opportunities for Growth with Carrier Ethernet Services

CSPs today are facing a perfect storm of market factors: IP NGN projects and transformations have tied up capital for the last decade; legacy voice and data services are all suffering revenue decline; while customers – both business and residential – continue to demand more for less.

The result: CSPs are faced with an environment of declining revenues and increasing costs while competitive pressures remain high. Survival requires standardization of both the network and the OSS/BSS platforms to minimize cost and to deliver a higher volume of services over the same infrastructure. To create revenue growth, CSPs have to deliver new and innovative service offerings in areas that are seeing market momentum. Carrier Ethernet services have become one such vehicle for delivering next-generation services.

Carrier Ethernet Gold Rush

Even through the recent global recession, Carrier Ethernet has continued to present a great opportunity for CSPs. In its June 2010 Ethernet and IP MPLS VPN Services report, Infonetics Research states that global revenue from Ethernet services was \$20.8B in 2009, up 23% from 2008, and predicts that it will grow at a robust CAGR of 14% to \$39.4B in 2014.

Consequently, investment in Carrier Ethernet equipment has also been growing. A November 2010 Carrier Ethernet Equipment report by Infonetics Research shows investments in Carrier Ethernet equipment was \$21.3B in 2009 and predicted to grow to \$32.2B in 2014 with a total investment of \$146B between 2010 and 2014.

Effectively, CSPs are rushing to Carrier Ethernet as a means of driving additional revenue and are doing so as rapidly as possible.

Chart 1: Carrier Ethernet Industry Growth

Source: 2010 Carrier Ethernet Equipment report – Infonetics Research

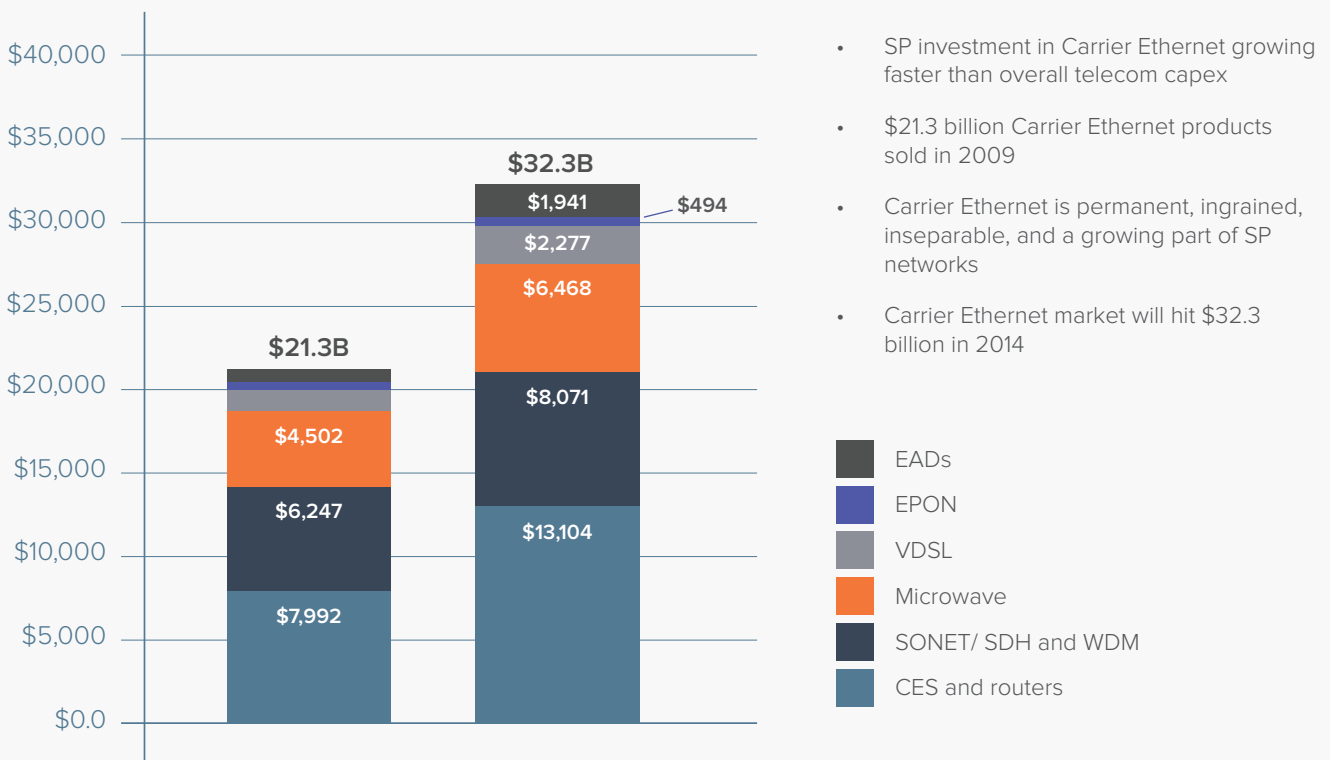

Carrier Ethernet Growth Drivers

The economic downturn has favored Carrier Ethernet Services for the following reasons:

- Ethernet-based services are cheaper per bit than alternative legacy and WAN services, and consumers and businesses have been turning to them to reduce their own expenses and meet their growing bandwidth needs.
- The ubiquity of Ethernet in the LAN makes it easy for customers to extend their products and services to Carrier Ethernet.
- Cloud computing and the virtualization of data centers are now mainstream strategies for enterprises to lower capital expenditures. For enterprises, Ethernet's flexibility makes it easier to set up connectivity for new services compared with private line, ATM, or Frame Relay technologies, ensuring faster time-to-market.
- For CSPs, since subsequent service changes can generally be done remotely, it also means lower costs and faster time-to-customer to process service upgrades. For example, CSPs can install a single 100Mb or GigE link at a new customer site for a low speed Internet connection, and later up-sell a higher speed connection without changing equipment at the customer or provider edge.
- Carrier Ethernet provides more flexible service offerings at lower costs, including methods to leverage segments of the legacy network such as Ethernet over SONET/SDH, so that these services can be implemented without necessarily replacing equipment.
- Altogether, the ubiquity, flexibility, and scalability of Ethernet allow CSPs to deliver bandwidth at a lower cost than legacy WAN services and are driving its growth and success.

While the success of Carrier Ethernet is notable, the question for CSPs is whether capital investment in Carrier Ethernet equipment is in itself enough? Will the CSP be able to effectively monetize these new assets? The answer is a potential "yes" but requires the CSP to effectively define, price and operate these new services according to industry-standard performance requirements. This is critical for customers and for effective management of the real-time nature of applications and traffic that Carrier Ethernet needs to support.



Building Differentiated Carrier Ethernet Services

While Carrier Ethernet services present a great revenue opportunity, the key to winning the battle against declining margins is ensuring that customers select the CSP's service offering over the competition. The industry has already adopted IP NGN to varying degrees – making it a commodity shared by all players, and hence an ineffective method of differentiation. However, leveraging their Carrier Ethernet investment, CSPs can differentiate through a combination of price, performance and the definition of the service offering itself. Effective service differentiation necessitates strong, service-aligned, performance management across all three of these dimensions.

Differentiation through Price – Reduce OPEX

For CSPs to have any flexibility in pricing their Carrier Ethernet-based market offerings, they must control the costs of delivering the offerings, i.e., operating expenses. Operational excellence driven by preventative maintenance requires effective performance management to reduce costs. For example, performance management's visibility into the performance of the network and its elements within the Carrier Ethernet service enables technicians to quickly identify and address potential problems before they become service-affecting and customer-impacting. This in turn leads to reductions in SLA compliance issues, lowers potential customer credits and claw-backs, and strengthens negotiating positions for future contract extensions.

Similarly, configurable and behaviour-based performance events that cover multiple instances and Key Performance Indicators (KPIs) allow for intelligent and integrated notification so that engineers can proactively identify true network problems without being bogged down by trivial and/or duplicate alarms. When problems do occur, a crucial element of performance management is granular, on-demand data collection for in-depth analysis of an identified performance issue. The ability to capture the service context, measure end-to-end visibility, and proactively alert support staff via intelligent performance events together drive significant reductions in SLA-defined MTTD (Mean Time to Detect) and MTTR (Mean Time to Repair). Meeting and exceeding service level expectations is critical to protecting margins and building pricing power.

Differentiation through Service Performance – Retain Customers and Grow Market Share

In a 2010 survey conducted by Atlantic-ACM, performance was the number one purchase driver for Metro Wholesale services – ranking 9.24 on a scale of 1 to 10 (10 being most important). This underscores the fact that the quality of the customer experience defines the value of the service offering. Thus CSPs must have meaningful metrics to measure the performance of their services across the network to ensure the highest perceived value and grow their market share.

This task is more challenging given that the end-to-end service may cross multiple operators' networks. Network service performance itself is not the only factor impacting overall customer experience. Another crucial element is the associated customer reporting. This reporting is the "proof-point" to customers that demonstrates their services are performing as designed, expected, and contracted.

Performance management should support the collection, processing, storage, and reporting of infrastructure health, traffic usage, and end-to-end service metrics (as well as formal SLA Management and customer reporting applications) to enable CSPs to market the performance of their network to retain and grow market share. Careful selection of standards-aligned performance management tools is critical given the large investments in Carrier Ethernet equipment. Without the right performance management tool, ensuring rapid delivery of differentiated service performance to the end customer is at risk.

Leveraging their Carrier Ethernet investment, CSPs can differentiate through a combination of price, performance and the definition of the service offering itself. Effective service differentiation necessitates strong, service-aligned, performance management across all three of these dimensions.

Differentiation through Service Offering Definition – Accelerate Growth

The Service Offering Definition is a method of differentiation with the greatest potential to increase a CSP’s top line revenue.

The Metro Ethernet Forum (MEF) has standardized service types and attributes such that the CSP is able to define various services targeted to the needs of specific business verticals.

Examples include an extreme low-latency service for financial institutions to handle their transactions, an on-demand distributed video service for covering a major sporting event where frame delay variance has strict requirements, or a fault prevention service in electrical transmissions to prevent damage to million-dollar transformer equipment.

These service offerings include not only the network service itself but can be supplemented with highly configurable customer dashboards for understanding and reporting on multiple aspects of service performance, such as:

- End-to-end service performance
- Early warning alerts on service capacity changes and requirements
- Identification of potential bandwidth savings
- Performance issues from the data center to the customer edge with in-depth application-layer visibility through techniques such as Deep Packet Inspection (DPI)

Chart 2: Drivers of purchase

Source: 2010 ATLANTIC-ACM Metro Carrier Report Card

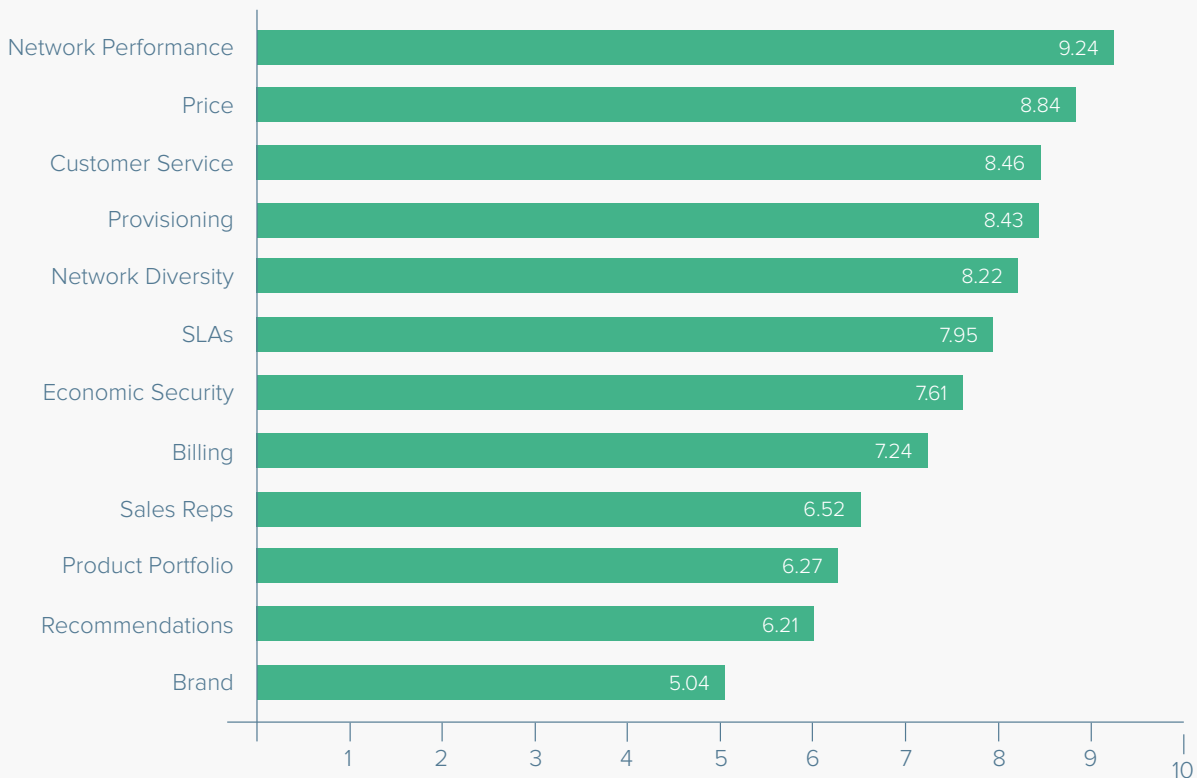

Metro wholesale customers rated how important each of the above criteria were to their metro service purchase decisions (1 = least important, 10 = extremely important)

Once a service is defined, time-to-market equates to time-to-revenue. A performance management solution that leverages Carrier Ethernet standards is necessary for quick and efficient deployment – despite the complexities of the underlying multi-vendor network. Such a solution should facilitate rapid deployment by leveraging industry standards and offering automated provisioning of the service topology via EMS integration with products such as Alcatel Lucent 5620 SAM or Cisco ANA. It should also support configurable APIs to enable integration with existing CSP inventory systems. These performance management capabilities minimize the operating expense required to deploy new products while accelerating the start of new revenue streams.

Although the definition of the service offering may be the most intricate method of differentiation, it is undoubtedly the most important to CSPs looking to grow and sustain their business.

Once a service is rolled out, it has to be monitored and measured over time. A performance management solution addresses this critical role – as the central repository for all performance data. Product managers in CSPs need performance management data for visibility into historical service usage in order to identify market opportunities and profitably craft new Ethernet services.

They also need it for tracking uptake of new services to justify future investments in Carrier Ethernet equipment. Engineering can also leverage the same service utilization data and can ensure that the infrastructure is in place to support the services being planned and delivered.

The Need for Performance Management Standardization

During the standardization of the core and the introduction of IP NGN architectures, CSPs must also reduce the number of tools required to manage and support their networks. Ultimately a common OSS framework is a key method for achieving the cost benefits of these standardized architectures. Performance management solutions must therefore be able to easily adapt to a common OSS framework through simple and effective integrations with fault, inventory, configuration, ticketing, and other management systems. (See Telstra Network Transformation Sidebar for a description of such a project).

“Single Source of Truth” on Performance Data

Many CSPs use multiple resources to track the performance of their networks, from legacy OSS applications to anecdotal customer feedback. Further, different functional groups often use different sources of information to make decisions, and consequently these decisions may often become misaligned. Ideally, a performance management solution should easily integrate with other OSS applications and become the central repository of network performance data for the entire organization.

With this architecture, all of the functional groups – Operations, Engineering, Service Management, and Product Management – are essentially united as a common workforce leveraging a “single source of truth” to make their decisions. CSPs are also able to decommission overlapping back office systems and applications, further reducing operating expenses and improving operational efficiencies. The result is a more efficient network management architecture and better decision making in daily network design and deployment activities.

Leveraging Standards to Accelerate Time to Market

The MEF (Metro Ethernet Forum), established in 2001, has led the effort to ensure carrier grade service, equipment interoperability, and compliance to management requirements across multiple carrier networks and end-user enterprises and has been a critical success factor to the explosive growth that the industry is witnessing today.

MEF technical specifications support the deployment of Carrier Ethernet services across multiple technologies (for example over Sonet/SDH, MPLS, native Ethernet, etc.) and domains (for example, business services, residential, and mobile backhaul transport).

This is especially useful while the industry continues to make the transition from legacy TDM to modern IP packet core networks.

MEF Performance Management Standards

The challenge for CSPs is to ensure that Carrier Ethernet services are delivering the value that their customers’ desire. To achieve this, CSPs need to make sure that their offerings are compliant with MEF specifications especially in regards to effective performance management and OAM (Operations, Administration and Maintenance).

Understanding the MEF specifications covering this area is therefore crucial to building out successful and profitable Carrier Ethernet services. Furthermore, the performance management solution needs to take into account the defined services and attributes – as well as monitor them end-to-end, leveraging the standards of the MEF and other relevant standards bodies like the ITU and IEEE.

Telstra Network Transformation Project – 2006

“Telstra is following the likes of BT, France Telecom, Telecom Italia, SBC and AT&T, which are all engaged in similar transformation projects. “There is a noticeable trend among large operators to overhaul and consolidate their OSS/BSS estate,” says Analysys’ Teresa Cottam. “The reason is that in the face of increasing competition, operators need to launch new services quicker, monetize them and tear them down more often.”

“In addition to Cramer, the incumbent selected five vendors – Amdocs, Syndesis, Metasolv, Infovista and VPI – for seven major work programs covering customer-service assurance, fulfillment, inventory-network planning, network-service assurance, enterprise-program management and service delivery.”

Handford, Richard (2006, August 7). Telstra sets high goals with its transformation strategy but will need a steady aim to score. OSS/BSS Analyst N° 814.

“Ultimately aiming to reach 95% of Australia’s business, Telstra claims its Next IP network will be the largest fully integrated national fixed/wireless IP network anywhere in the world. It is building a national carrier grade IP network which transforms the system from core to edge replacing circuit switches with soft switches. Following an ambitious timetable, Telstra plans to build a core IP/MPLS network within two to five years in a project which will transform its systems, processes and services.

The IT infrastructure is being redesigned to automate and integrate back and front office processes thereby reducing its 1200 BSS/OSS systems by 75% over three years. All existing 400 platforms, 1000 products numerous fixed, mobile and data networks are being consolidated.

The overall budget for network development is over \$10 billion and Telstra is spending \$1 billion on IT.”

Awde, Priscilla (2008, January 7). Congratulations for Making a Difference. Global Telecoms Business N° 95.

“In 2009, Telstra declared its four-year network transformation project a success, despite a \$1.5B increase in the overall budget. Telstra attributed the increases in the project budget to an increase in the project’s scope and added complexity in some areas, such as data migration. The project delivered \$307M in cost savings and additional revenue in the 2009 financial year, and these benefits were projected to grow to \$1.2B over the next two years.”

Sharma, Mahesh (2009, October 29). Telstra closes book on ‘transformation’. Australian IT.

Retrieved from <http://www.australianit.news.com.au/story/0,27574,26275597-15306,00.html>

Leveraging Standards to Accelerate Time to Market

The MEF (Metro Ethernet Forum), established in 2001, has led the effort to ensure carrier grade service, equipment interoperability, and compliance to management requirements across multiple carrier networks and end-user enterprises and has been a critical success factor to the explosive growth that the industry is witnessing today.

MEF technical specifications support the deployment of Carrier Ethernet services across multiple technologies (for example over Sonet/SDH, MPLS, native Ethernet, etc.) and domains (for example, business services, residential, and mobile backhaul transport). This is especially useful while the industry continues to make the transition from legacy TDM to modern IP packet core networks.

MEF Performance Management Standards

The challenge for CSPs is to ensure that Carrier Ethernet services are delivering the value that their customers' desire. To achieve this, CSPs need to make sure that their offerings are compliant with MEF specifications especially in regards to effective performance management and OAM (Operations, Administration and Maintenance). Understanding the MEF specifications covering this area is therefore crucial to building out successful and profitable Carrier Ethernet services. Furthermore, the performance management solution needs to take into account the defined services and attributes – as well as monitor them end-to-end, leveraging the standards of the MEF and other relevant standards bodies like the ITU and IEEE.

About the MEF



The MEF is a global industry alliance comprising more than 150 organizations including service providers, Cable MSOs, equipment and software vendors, semiconductor companies, and testing organizations. Its mission is to accelerate the adoption of Carrier-class Ethernet networks and services.

To this end, it develops technical specifications and implementation agreements to promote interoperability and deployment of Carrier Ethernet networks worldwide. Since its inception, it has authored more than 25 specifications that have directly contributed to the definition and standardization of Carrier Ethernet services around scalability, reliability, quality of service, and service management.

With its work, the MEF brings the compelling business benefit of the Ethernet cost model to achieve significant savings for end-user customers, network operators, and service providers.

MEF Definitions for Carrier Ethernet Performance Management

Considering the dynamic and ubiquitous nature of Carrier Ethernet, performance management is needed right from the moment of service activation. This is because business-driven Service Level Agreements (SLAs) are more stringent than ever, and changes to subscribership, customer usage, end-to-end connectivity paths, and traffic engineering policies are constant. As Carrier Ethernet replaces legacy technologies one must constantly supervise the performance and quality of Carrier Ethernet services across three dimensions: infrastructure health, service utilization, and end-to-end service quality.

Basic MEF Definitions of Carrier Ethernet Service Types

The basic model of a Carrier Ethernet service as defined by the MEF envisions customer equipment connecting to a service provider’s Carrier Ethernet network via a User Network Interface (UNI).

The UNI is the physical port or interface that acts as the demarcation point between the customer and the provider’s network and is always owned by the latter. An association of two or more UNIs that limits the transport of Ethernet frames among them constitutes an EVC (Ethernet Virtual Connection). The EVC is a service container that connects two or more customer sites through Carrier Ethernet transport. EVCs support three broad types of Carrier Ethernet services – E-Line, E-LAN and E-Tree – with both a port-based as well as VLAN-based flavor for each as explained in Figure 1 below.

Data moves in a Carrier Ethernet network between two UNIs by traversing the transport layer, allowing Carrier Ethernet services to be technology agnostic and offer easy interoperability across different operator, provider, and customer interconnects. At the same time, multiple Class of Service (CoS) attributes for each service type can help CSPs create segmentation and value for their offerings. The CSP must therefore ensure the ability to measure and monitor their services with respect to these attributes to demonstrate the value to their end customers.

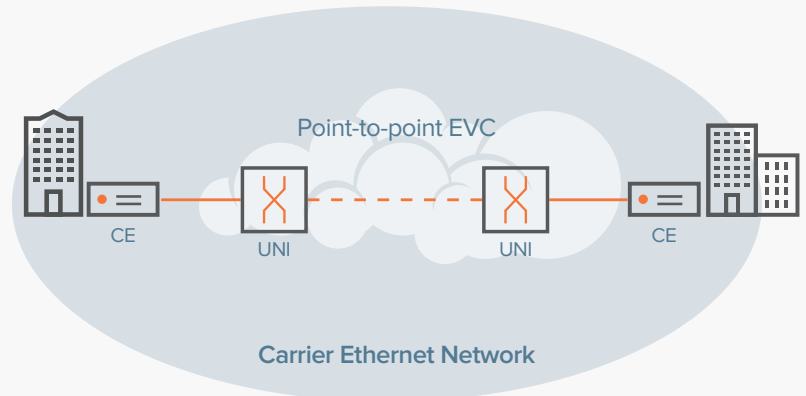

Figure 1: Types of Carrier Ethernet services

E-LINE SERVICE TYPE

Point-to-point EVC that supports offerings like TDM private line replacement (through dedicated UNIs) or ATM/FR replacement (supporting multiple virtual connections to a single UNI through service multiplexing)

- Ethernet Private Lines
 - Virtual Private Lines
 - Ethernet Internet Access
-



E-LAN SERVICE TYPE

Multipoint EVC that is used to create Layer 2 VPNs, transparent LAN services and the transport foundation for IPTV and multicast networks

- Multipoint L2 VPNs
 - Transparent LAN Service
 - Foundation for IPTV and Multicast Networks, etc.
-

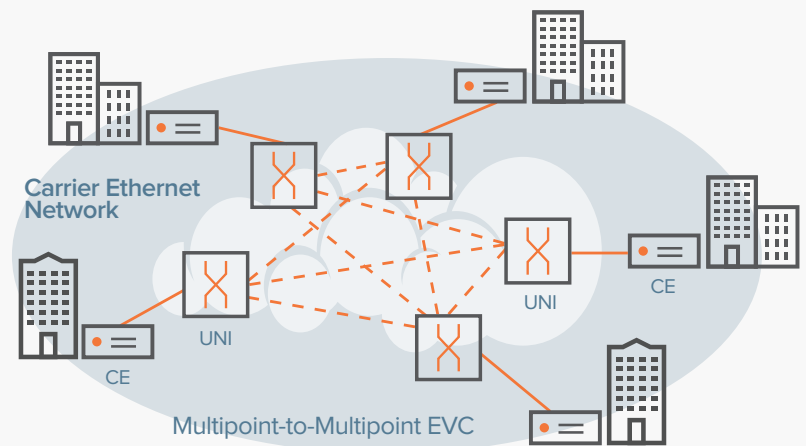

E-TREE SERVICE TYPE

Rooted-multipoint EVC that prevents wasteful transport to network “leaves” and enables efficient point-to-multipoint connections for franchised and multihost applications that need built-in traffic separation

- Video on Demand Service
 - Internet Access
 - Triple-play Backhaul
-

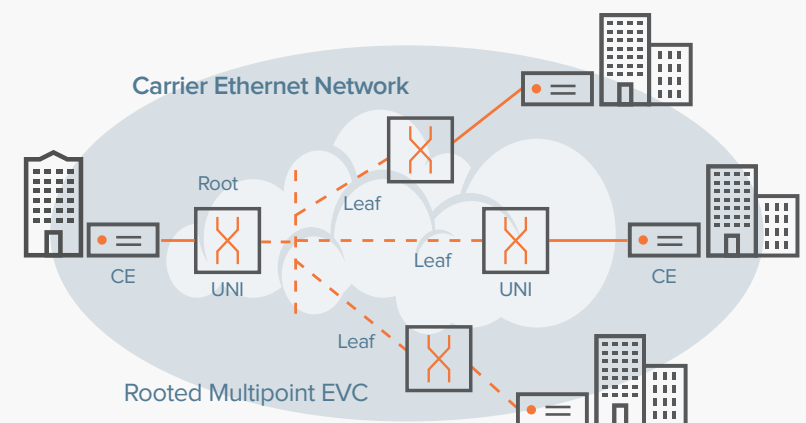

Carrier Ethernet Traffic Profiles

An important aspect of measuring Carrier Ethernet service utilization is to account for traffic profiles which control the rate at which frames can traverse a customer interface (UNI) to manage available resources and allow for bandwidth changes on demand. A typical Carrier Ethernet traffic profile consists of the parameters shown in Table 1 below that would be established on UNIs, EVCs, and/or by CoS.

MEF Standards for Performance Management

Performance management solutions monitoring different Carrier Ethernet service types and their SLA compliance to traffic profiles necessarily need to adhere to MEF-defined specifications in order to translate the technology and management interoperability into the service operations domain.

Specifically, the performance management solution should understand and adhere to the following MEF and related standards:

MEF 15: Requirements for Management of Phase 1 Carrier Ethernet Network Elements (Published November 2005)

This specification focuses on what is considered to be the essential network management functionality of Carrier Ethernet Network Elements (CE-NEs) supporting Ethernet Service as defined in MEF10. The CE-NE is a Provider Edge network element supporting carrier class Ethernet Services. Specifically with respect to performance management, the specification defines the collection and analysis of data to assess a resource's ability to carry out its function.

MEF 17: Service OAM Requirements and Framework (Published April 2007)

OAM (Operations, Administration, and Maintenance) can be used to manage network infrastructures and services provided across them. This document provides requirements and the framework for Service OAM within MEF compliant Carrier Ethernet Networks (MENs).

Service OAM requirements represent expectations of CSPs in managing Ethernet Services within the MENs and the expectations of subscribers in managing Ethernet Services across the MENs.

Service OAM framework describes the high-level constructs used to model different MENs and service components that are relevant for OAM.

Specifically with respect to performance management, CSPs need to:

- Monitor the connectivity status of other elements (active, not active, partially active)
- Estimate Frame Loss Ratio (FLR) Performance: given as the percent of lost frames as defined in MEF 10
- Estimate Frame Delay (FD) Performance: given as time required to transmit a service frame from source to destination UNI as defined in MEF10
- Estimate Frame Delay Variation (FDV) Performance: given as the difference in delay of two service frames as defined in MEF 10

MEF 10.2: Ethernet Services Attributes Phase 2 (Published October 2009)

This document describes Ethernet Service attributes. The Ethernet Services are modeled from the point of view of the subscriber's equipment referred to as the Customer Edge that is used to access the service. The basic elements of Ethernet Services are defined. In addition, a number of Service Attributes are defined that may be offered as part of an Ethernet Service including the definition of Service Level Specification.

Critical to effective performance management of Carrier Ethernet services is the ability to understand the service and its attributes and provide Key Performance Indicators (KPIs) within the service context.

Performance management solutions monitoring different Carrier Ethernet service types and their SLA compliance to traffic profiles necessarily need to adhere to MEF-defined specifications in order to translate the technology and management interoperability into the service operations domain.

Table 1: Traffic profile parameters

Parameter	Description	
CIR (Committed Info Rate)	The maximum rate at which service frames can be delivered, on average. CIR settings limit the frame size to emulate speed throttling, e.g.: speeds such as 2Mbps, 10 Mbps, 50 Mbps over a 100 Mbps 802.1 interface. CIR will need to meet end-to-end service level objectives	Frame rates above the CIR (and frame sizes above the CBS) may be discarded, depending on the EIR parameter
CBS (Committed Burst Size)	CBS is the maximum allowable frame size in accordance with the CIR	
EIR (Excess Information Rate)	The maximum rate at which service frames can be delivered above the CIR, on average. These frames will have no service level objective	Frame rates and sizes above the EIR and EBS are subject to discard
EBS (Excess Burst Size)	EBS is the maximum allowable frame size in accordance with EIR	

Performance Monitoring Standards from outside the MEF

The MEF references, contributes, and utilizes a number of external standards that provide definition to performance management aspects of Carrier Ethernet Services. These include the following:

- IEEE 802.3ah**
 For link-based connectivity, this standard focuses on tools for link monitoring, remote failure indication, and remote loopback on a link.
- IEEE 802.1ag**
 Connectivity fault management provides tools for service-level OAM and detecting, isolating, and reporting connectivity faults in a provider network.

- ITU Y:1731**
 Covers connectivity management and also provides tools to measure performance parameters for a service such as Frame Loss Ratio, Frame Delay, and Frame Delay Variance.

To incorporate the measurements, metrics and processes defined in the above standards, the chosen performance management solution has to have the capability to capture the Carrier Ethernet service model and attributes, collect the raw data from the equipment and EMSs, and process them into meaningful KPIs.

We will discuss the kinds of KPIs needed for effective performance management in the next section.

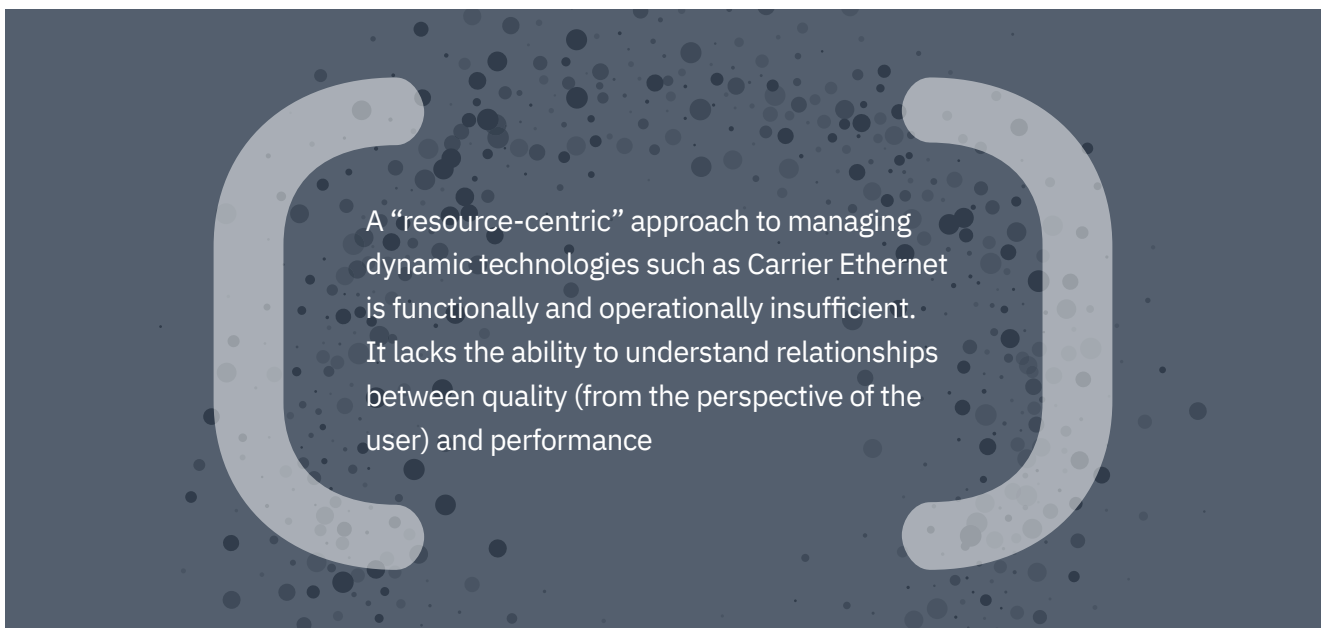

KPIs for Carrier Ethernet Service Performance Assurance

A “resource-centric” approach to managing dynamic technologies such as Carrier Ethernet is functionally and operationally insufficient. It lacks the ability to understand relationships between quality (from the perspective of the user) and performance (from the perspective of the technology) to ensure proactive customer satisfaction and SLA protection.

A “service performance assurance” approach to performance management provides that ability, including proactive analysis and preemptive alerting that can map customers to service levels and deliver visibility into relationships between end-to-end performance and network elements (CE-NEs). In doing so, this approach to performance management allows for the prioritization of identified performance problems, troubleshooting, end-to-end service level management, and proactive capacity planning based on customer, service, and resource impact.

Types of KPIs

Collectively there are three dimensions (Resource, Traffic and End-to-End) to effective performance management of Carrier Ethernet services requiring three types of KPIs:

- **Resource KPIs** for monitoring of resource capacity (CE-NEs) as per MEF 15 guidelines
- **Traffic KPIs** for transport bandwidth profiling and usage analysis based on MEF 10.2, 15 and 17 guidelines
- **End-to-End KPIs** for E2E Carrier Ethernet service monitoring as per MEF 10.2 service attributes and MEF 17 OAM guidelines

These 3 dimensions are needed in combination to confirm service levels, anticipate capacity limitations, detect problems as they develop, and troubleshoot. Figure 2 below shows the performance information sources for producing vendor-agnostic KPIs.

Figure 2: The three types of KPIs

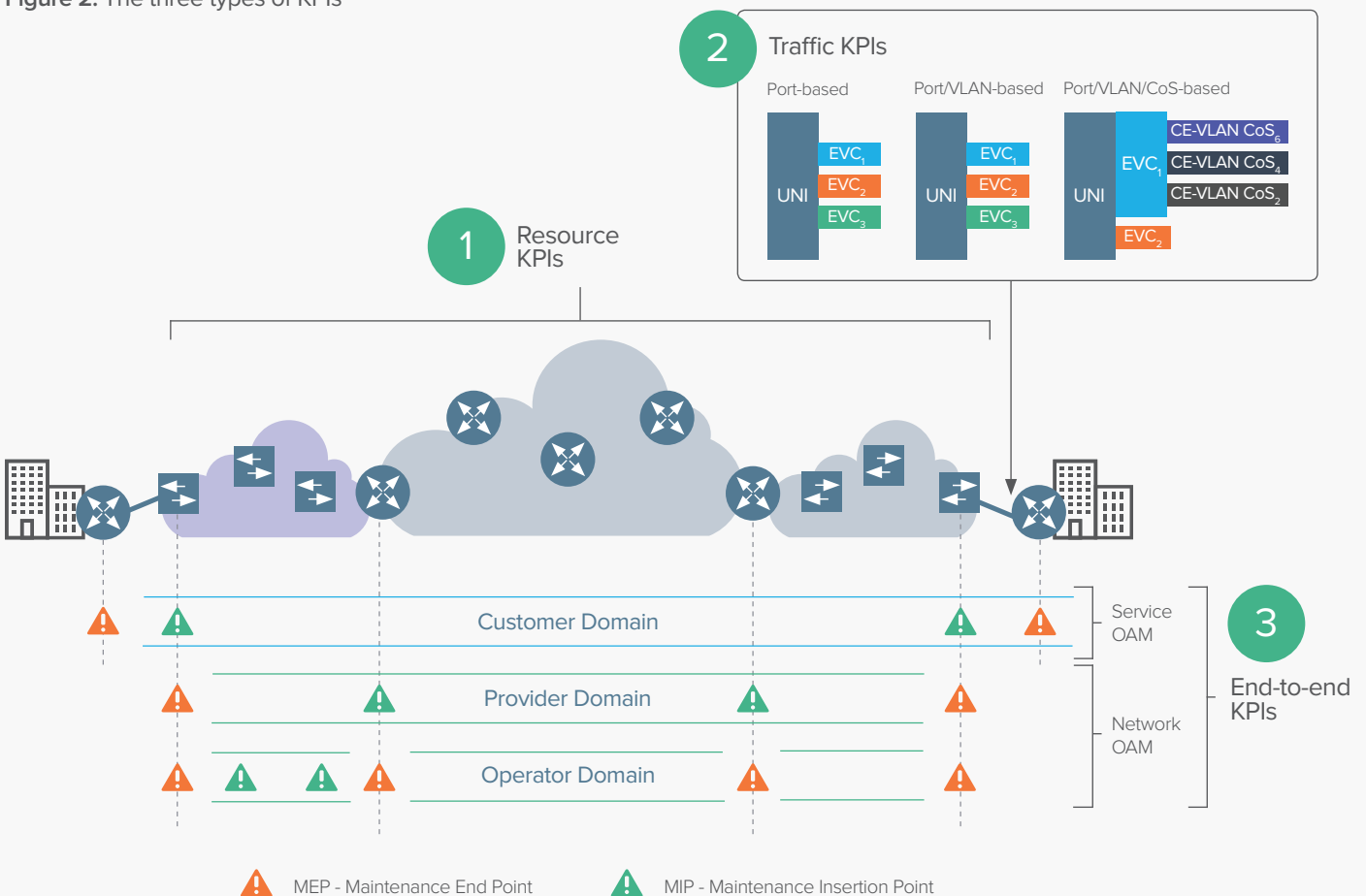

Resource KPIs

Basic resource monitoring in principle is a straightforward process; however, monitoring the behavior of Carrier Ethernet networks in the context of the Ethernet service and underlying technologies (e.g. MPLS) is key for optimal performance management. Table 2 demonstrates multiple methods of performance data collection. Carrier Ethernet and core network equipment such as routers, WAN switches and Multi-Service Provider Edge (MSPE) devices often leverage SNMP MIBs which produce rich sources of information on physical and virtual interfaces, and the physical platform itself. Polling and storing this data is easy enough, as long as there is a solid understanding of standard and proprietary MIBs from leading Carrier Ethernet equipment vendors. Selecting, analyzing and aggregating the relevant data on a large scale requires a flexible, robust, standards-based performance management foundation. The result is a set of Resource KPIs and detailed troubleshooting metrics that deliver real value.

Some equipment vendors offer Element Management Systems (EMS) that supports the configuration, provisioning, and detailed monitoring of their own devices. Examples of popular EMSs include the Alcatel-Lucent’s 5620 Service Aware Manager (SAM) and Cisco’s Active Network Abstraction (Cisco ANA) products. As described in MEF 7 and revised in MEF 7.1, the performance management component in the NMS (Network Management System) can greatly benefit from collecting

data directly from the EMS instead of direct polling of network elements.

This is due to the following reasons:

- The performance data is gathered by an EMS in a controlled way with rich contextual information on both element utilization and service attributes.
- The need for double-polling is eliminated.
- NMS and EMS vendors can offer pre-packaged integrations that can help providers get to market faster with new Carrier Ethernet service offerings.

Thus the performance management solution needs to be able to leverage these data sources in addition to direct polling methods such as SNMP.

Table 3 provides a non-exhaustive list of KPIs that are the most important to managing Carrier Ethernet performance and service levels.

The analysis behind these KPIs is not particularly complex, involving raw-to-rate and other basic calculations. More advanced KPIs can be obtained when performing aggregation, abstraction and analysis with respect to the overall service as described in the next section.

Carrier Ethernet services will have QoS policies imposed to make them more reliable and deterministic. The network KPIs listed in Table 3 are derived with respect to each CoS within each VLAN, where available. This includes UNIs or EVCs that carry only one CoS level.

Table 2: Performance management data collection methods

Method	Complexity	Carrier Ethernet Value
SNMP Standard MIBs	★	★
SNMP Proprietary MIBs	★★	★★★★
TL1	★★★	★★
CLI	★★★★	★★★
CORBA/ XML	★★★★	★★★★

Traffic KPIs

Even with traffic profiles and QoS policies in place, it is still necessary to monitor the traffic not only for anomalies due to shifting usage patterns or misconfigurations but also for long term trending. Traffic KPIs required include:

- Traffic to/from CE site
- EVC Utilization
- EVC Frames Discarded
- Queuing Discards
- Submitted traffic
- Transmitted traffic
- Dropped traffic

With all three types of KPI measurements in place – covering infrastructure health, service utilization, and end-to-end service quality – the final element is to ensure all dimensions are tied to the service context; that is the Ethernet Virtual Circuit along with its defined Service Type and Attributes.

End-to-End KPIs

The purpose of Carrier Ethernet is to deliver a service which is inherently end-to-end, thereby driving the necessity for end-to-end measurements that can confirm delivery of those services. End-to-end measurements such as those defined by Ethernet OAM, play an important role in determining service quality, irrespective of the devices between.

Single or round trip Frame Delay Performance and Frame Loss are simply not available otherwise. For example, by delivering Carrier Ethernet service frames between Layer 2 network end-points (UNIs) and measuring the round trip results, the ability of the network to support the end-user can be validated. Leading equipment vendors support the creation of test “probes” within their equipment (e.g., Cisco IP SLA Ethernet, Alcatel-Lucent MAC Ping, Adva Etherjack Service Assurance, etc.). Test traffic is generated by the “sender” (Ethernet Switch/Router) to the “target” (responder).

The performance management solution should align with MEF 17 Technical Specification on End-to-End Service OAM and support KPIs such as those in Table 4.

Table 3: Resource KPIs

	KPI	Description
Device KPIs	Availability	Percentage of time a physical or logical resource is available for use. A variety of protocols (such as SNMP and ICMP) are typically used.
	CPU, Memory, Buffer Utilization	Calculated as percentage of capacity. Excessive levels, either individually or in combination, indicate resource overloading which can result in delays in data transfer and a high rate of packet errors or dropped packets
Network KPIs	CIR Utilization	Percentage of customer utilization levels relative to the CIR.
	Queue Drop	Discarded packets, including those measured as Tail and Random drop. Implies congestion or improper CoS policy, too much over-provisioning and/or excessive customer usage beyond capacity.
	Errors	The percentage of frames or packets that were detected in error during transmission and were discarded. An excessive error rate causes a high incidence of retransmission. This can be an indication of the quality of the transmission line.
	Dropped Frames	Measured relative to submitted and transmitted traffic, dropped traffic is an indicator of congestion or improper CoS policy. Also based on the number of frames discarded due to frame rates and frame sizes in excess of EIR/EBS.

Table 4: End-to-end KPIs

Parameter	Description	Technique
Availability	Percentage of time a device or interface is available for use	Frame rates above the CIR (and frame sizes above the CBS) may be discarded, depending on the EIR parameter
Frame Delay (Response Time)	One way and round trip delay of layer 2 transactions	Collection of OAM instrumentation through SNMP/CLI or EMS integration
Frame Delay Variance	Variation of delay	Collection of OAM instrumentation through SNMP/CLI or EMS integration
Frame Loss Ratio	Percentage of undelivered frames compared to total number of frames submitted	Collection of OAM instrumentation through SNMP/CLI or EMS integration

Figure 3: Populating the Carrier Ethernet performance management service model

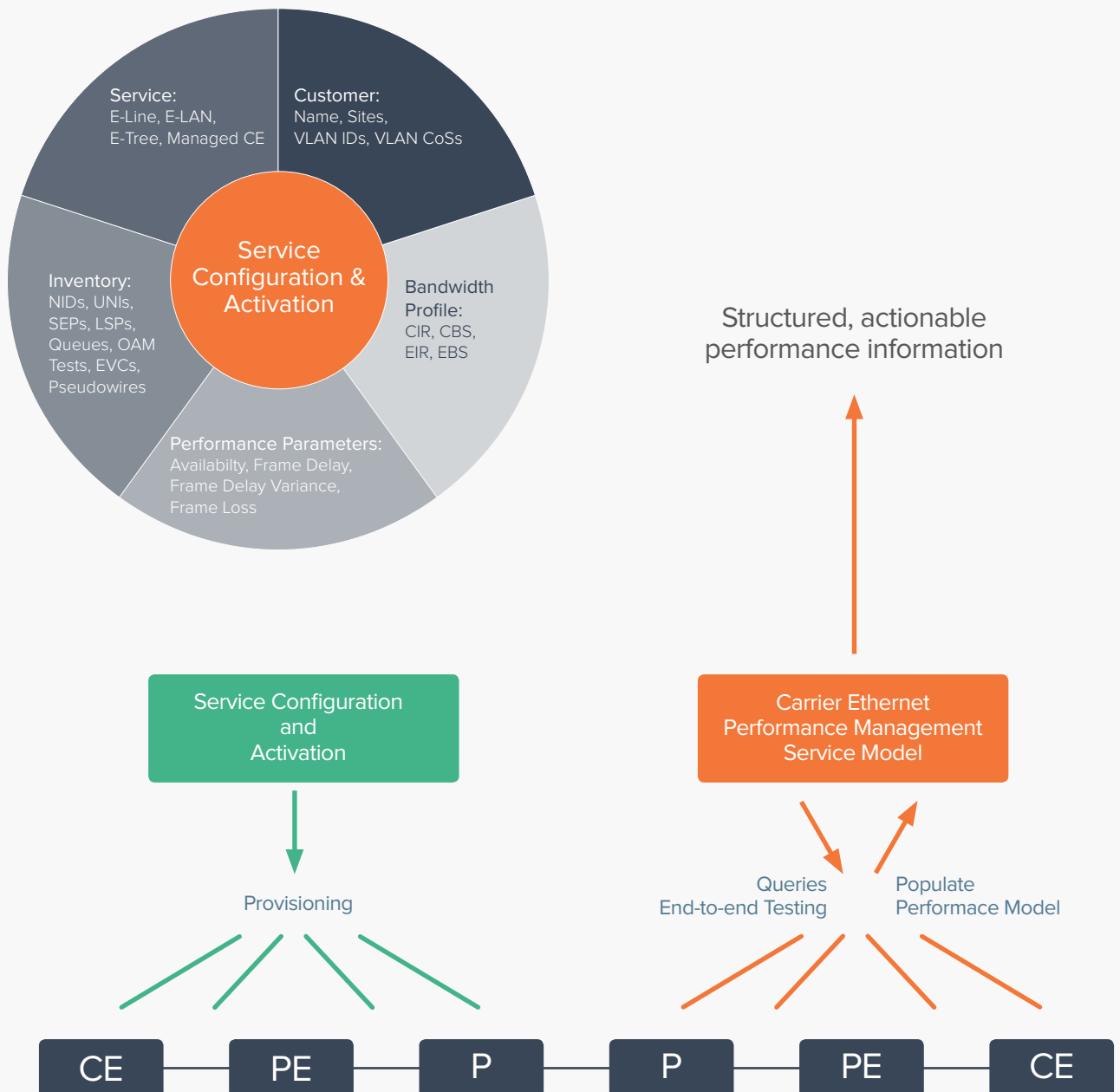

Service Modeling for Carrier Ethernet Performance Assurance

Carrier Ethernet services require performance measurements against customer SLAs as defined between customer's UNIs.

These measurements require service modeling to capture and understand relationships between resources, the services they support, the customers subscribing to those services, and their respective performance indicators.

The service model is fed by inventory, service, customer, bandwidth profile, and performance parameters from service activation and provisioning systems. The automatic feed of information to the model during provisioning plays a critical role in terms of immediacy, accuracy, and operational efficiency.

The same process performed manually on a multi-customer, multi-service scale is simply not feasible, nor accurate.

Vendor EMS solutions such as Cisco ANA and Alcatel-Lucent 5620 SAM, as well as multi-vendor OSS provisioning platforms such as those offered by Comptel, Amdocs, and Amartus provide proven Carrier Ethernet provisioning solutions that are capable of delivering service-centric topology feeds to performance management.

As configuration changes are made and customers are added, the model is dynamically updated so that the correct resources can be monitored relative to all the appropriate service and customer dimensions, as indicated in Figure 3.

The model therefore provides a structure for gathering, storing, aggregating, organizing, and locating information.

Conclusion

For CSPs to effectively capitalize on the opportunity provided by the Carrier Ethernet services market they must be able to bring these new service offerings to market quickly and efficiently despite the inherent complexities of service delivery over the converged IP NGN architecture. They must also be able to differentiate their service offerings based on attributes of their performance. Lastly they need to be able to competitively price these services. performance management is a critical element of this service differentiation with respect to price, performance, and definition of the service offering. Through minimizing Opex with a MEF-aligned, OSS interoperable, single source of truth for service performance, CSPs can offer high-value Carrier Ethernet services at the lowest cost to support flexible and competitive pricing.

By leveraging the critical purchase driver – performance – CSPs can accelerate time to revenue and market growth. With advanced service utilization tracking and analysis from the performance management solution, CSPs can best adapt and define new services with high service uptake and effectively monetize their infrastructure by immediately addressing (and charging for) identified capacity needs through automated trend analysis. They can also incur savings by minimizing over-provisioning across the service infrastructure. With innovative service definitions including not only the network service itself but the associated customer reporting options and enhancements, the CSP can differentiate its offerings in the market. Customer reporting can be leveraged to positively impact overall customer experience as well as directly generate additional revenue from premium reporting – including self-service dashboards for customer-based diagnostics, performance notifications, service capacity notifications, and automated upgrades based on detected usage patterns.

Effective performance management is therefore a key factor in fully leveraging Carrier Ethernet services to achieve economic sustenance and growth for CSPs. However, CSPs need to choose their performance management solution wisely, taking care that it adheres to key industry standards like those from the MEF with all of the underlying capabilities around Carrier Ethernet service modeling.

About Infovista

Infovista, the leader in modern network performance, provides complete visibility and unprecedented control to deliver brilliant experiences and maximum value with your network and applications. At the core of our approach are data and analytics, to give you real-time insights and make critical business decisions. Infovista offers a comprehensive line of solutions from radio network to enterprise to device throughout the lifecycle of your network. No other provider has this completeness of vision. Network operators worldwide depend on Infovista to deliver on the potential of their networks and applications to exceed user expectations every day. Know your network with Infovista.